

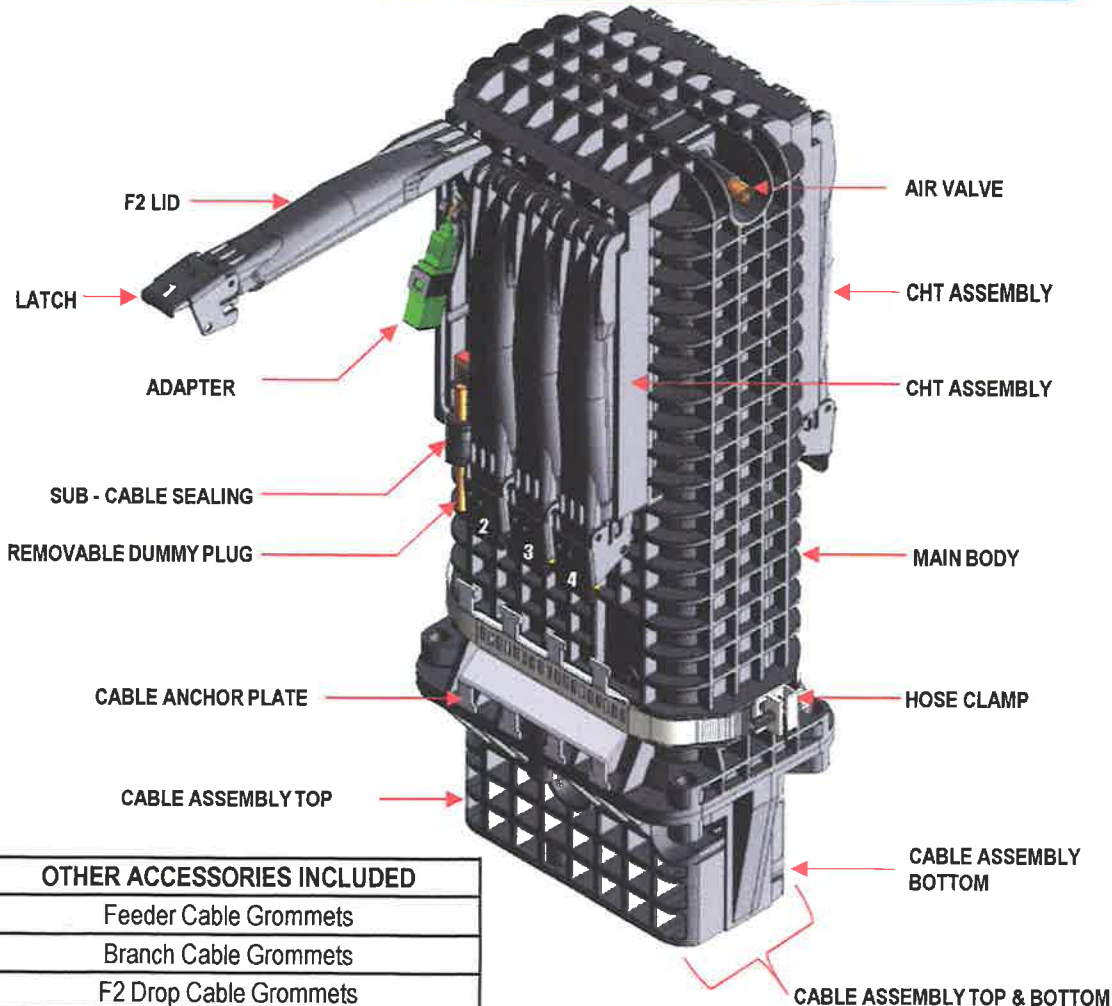

PEACOC® Mid-span Clamshell Hardened Terminal Quick Installation Guide

A PEACOC® MID-SPAN CLAMSHELL HARDENED TERMINAL PARTS



OTHER ACCESSORIES INCLUDED

Feeder Cable Grommets

Branch Cable Grommets

F2 Drop Cable Grommets

Silicone Grease

40mmL Splice Protection Sleeve

Mounting Kits and Accessories (optional)

B

1

Prepare the cable. Strip the jacket of the cable for about 7 ~ 8ft.

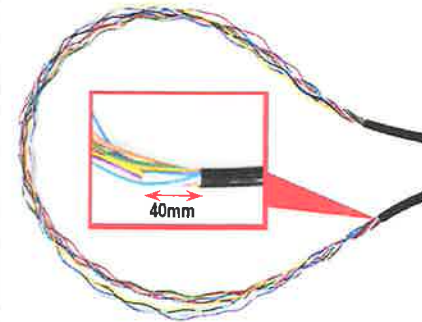

Cut the central membrane. Leave 40mm of the membrane from both ends of the jacket.

3

Insert the cable on the cable grommet with silicone grease. Install the cables on the cable clamp and tighten the screws with lock washers.

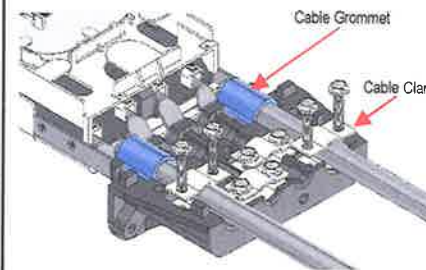

Put back the Cable Assembly Top and tightened the three (3) screws

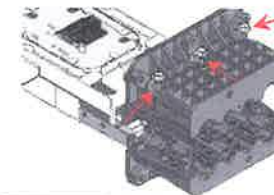

F1 CLAMPING & SPLICING

2

Loosen the six (6) screws on Main Body and slide down the Cable Assembly Top & Bottom.

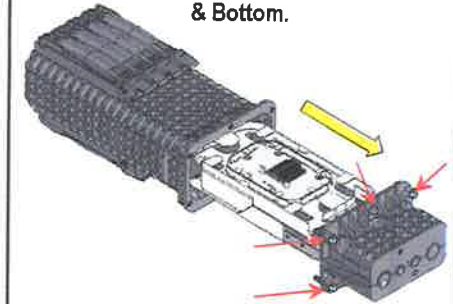

Then loosen the three (3) screws on the Cable Assembly Top & Bottom to remove Cable Assembly Top

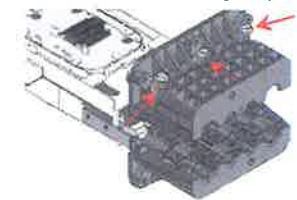

4

Store the unused tubes on the Express Cable Tray, and separate the needed buffer tube for splicing.

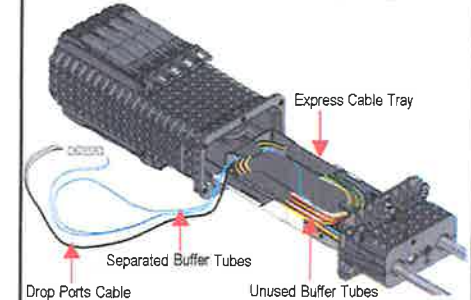

Splice the separated buffer tube fibers with the drop ports fibers. Store the fibers in the Splice Tray after splicing.

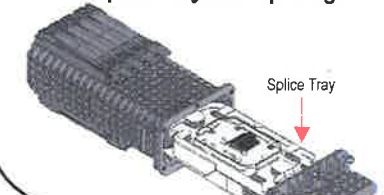

PEACOC® Mid-span Clamshell Hardened Terminal Quick Installation Guide

C STRAND MOUNTING

1 Install Strand Mounting Kit A using hex head slotted screws and tooth-lock washers. Air valve must be facing front side.

Hex Head Slotted Screws (2pcs)
Tooth-lock Washers (2pcs)
TOP VIEW
SIDE VIEW
Air Valve
Strand Mounting Kit A

2 Install Strand Mounting Kit B using hex head slotted screws and tooth-lock washers.

Hex Head Slotted Screws (2pcs)
Tooth-lock Washers (2pcs)
TOP VIEW
SIDE VIEW
Strand Mounting Kit B

3 Insert the strand wire/cable on the D-Clamp teeth. Fasten the hex nut using wrench.

D-Clamp

D POLE/WALL MOUNTING

1 Before going up the pole, fix the Mounting Kit Upper Plate on top part of the enclosure using hex head slotted screws with tooth-lock washers. Air Valve must be facing the front side.

Hex Head Slotted Screws (2pcs)
Tooth-lock Washers (2pcs)
Mounting Kit Upper Plate
Air Valve

2 Mount the Mounting Kit Lower Plate on the pole or wall using standard mounting screws. Insert the hose clamp on the slot from the side.

Mounting Kit Lower Plate
Hose Clamp

3 Position the enclosure on the Pole Mount Lower Plate, and wrap around the hose clamp on it. Tighten the hose clamp on the lower horizontal ribs and above the cable anchor plate. Ports 1 to 4 must be facing left side.

Mounting Kit Lower Plate
Hose Clamp
Cable Anchor Plate

4 Fix the Mounting Kit Upper Plate on the pole or wall using standard mounting screws.

Mounting Kit Upper Plate
Air Valve

NOTE: Mounting screws for pole or wall mounting are not included.

PEACOC® Mid-span Clamshell Hardened Terminal Quick Installation Guide

F2 DROP CABLES INSTALLATION

1 Pull the front part of the Lever to unlock the Lid



2 Lift the lid to access the adapters



3 Remove the dummy plug on the sub-cable sealing

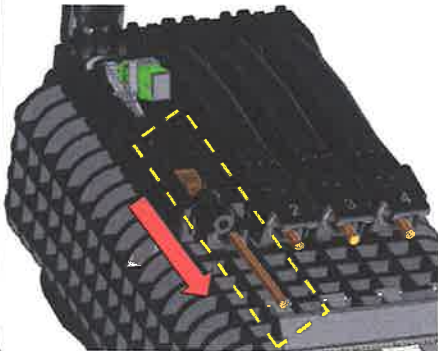

4 Patch connector on the adapter



5 Insert cable on the slit of the sub-cable sealing.

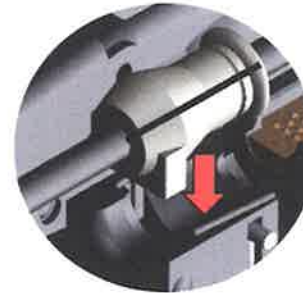

Use appropriate grommet for the type of cable being used.

7 Push back the front part of the lever to lock the lid.



F2 DROP CABLES INSTALLATION

6 Position the cables on top of the Cable Anchor Plate. Fix it using cable ties on both anchor ends.



NOTE: Make sure that the grommet is oriented as shown above.

△ Caution: Failure to properly orient the F2 grommet will compromise the sealing characteristics.

For Below-Grade Installation, application of **SILICONE GREASE** on four (4) grommets and the surface of the gaskets must be done before closing the unit.

NOTE: Before patching the connector to the adapter, clean the end of the drop according to company procedures.
△ Warning: Failure to follow the procedures can result in damage to optical fiber cable which may further result in a loss of service for active subscribers.